

THIS DRAWING IS UNPUBLISHED. RELEASED FOR PUBLICATION
 © COPYRIGHT BY TYCO ELECTRONICS CORPORATION. ALL INTERNATIONAL RIGHTS RESERVED.

LOC	DIST	REVISIONS			
P	LTR	DESCRIPTION	DATE	DWN	APVD
AF	50	H3	REVISED PER ECO-10-025913	22DEC10	HMR GJ

- 1 CONTINUOUS STRIP ON REELS.
- 2 (1) 0.8mm²[#18] AWG - 2.84 [.112] AND
(1) 1.3mm²[#16] AWG - 3.12 [.123] MAX DIA.
- 3 0.003302 [.000130] MAX PRE-TIN PLATE.
- 4 SPECIAL LUBRICANT.
- 5 PRELIMINARY - NOT FOR PRODUCTION.
- 6 NICKEL PLATED.
- 7 PRODUCT SPECIFICATION DOES NOT APPLY TO PART NUMBER 770642-3

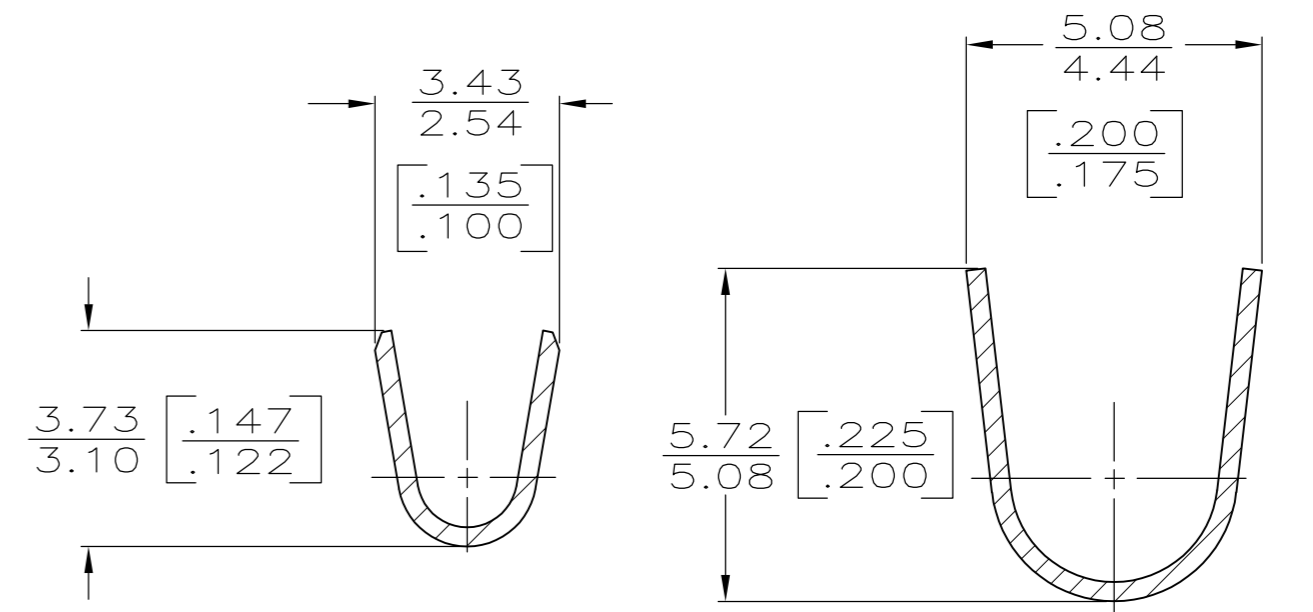
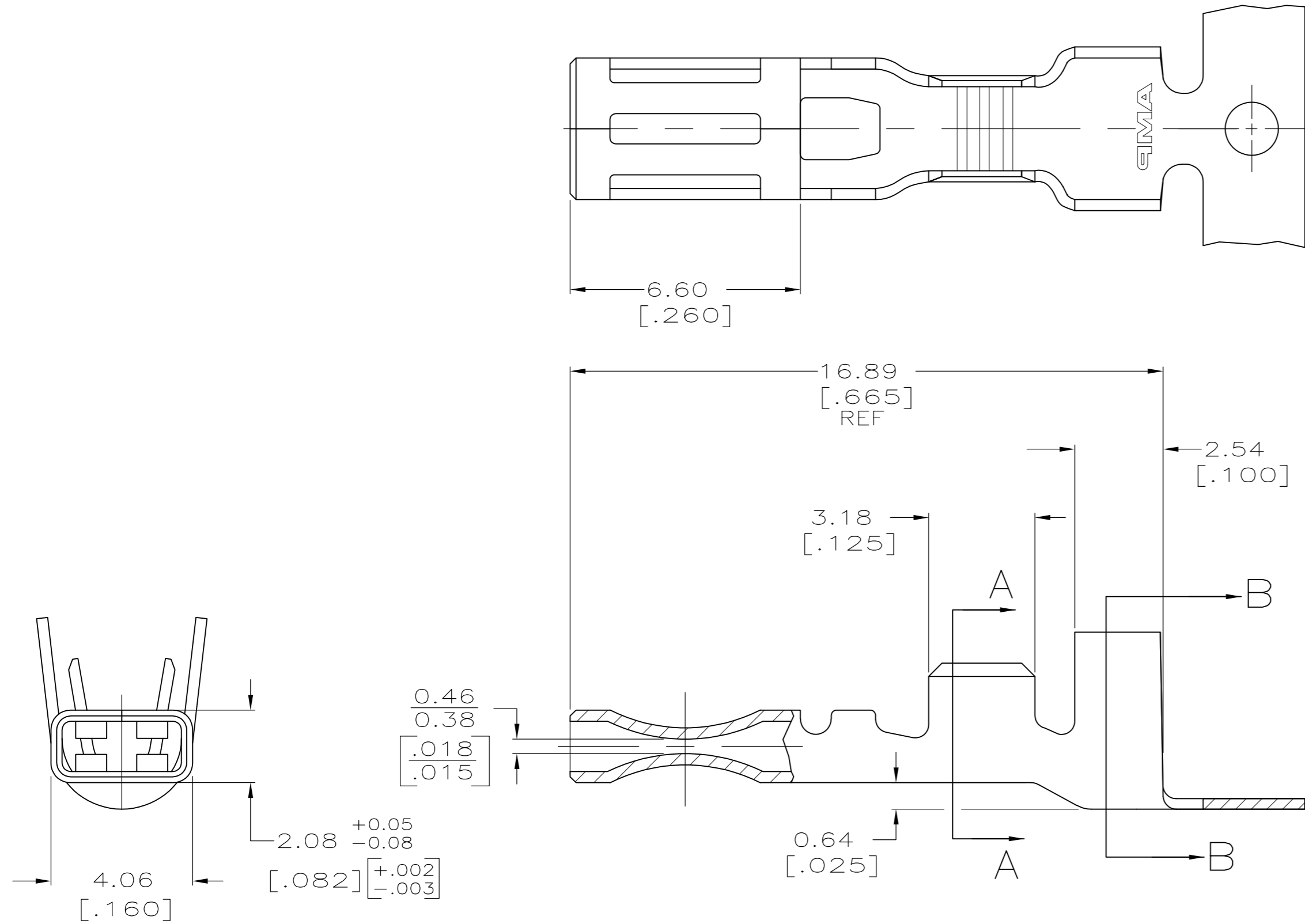

SECTION A-A

SECTION B-B

6	4	2	0.5 -2.0mm [20-14] AWG	770642-3
3	4	2	0.5 -2.0mm ² [20-14] AWG	770642-2
3	-	2	0.5 -2.0mm ² [20-14] AWG	770642-1
FINISH	LUBRICANT	INSULATION RANGE	WIRE RANGE	PART NUMBER
THIS DRAWING IS A CONTROLLED DOCUMENT.		DWN MICHAEL S. FEHER 02FEB2004 CHK DONALD F. DECKER 02FEB2004 APVD DONALD F. DECKER 02FEB2004	Tyco Electronics Corporation Harrisburg, PA 17105-3608	
DIMENSIONS: mm [INCHES]	TOLERANCES UNLESS OTHERWISE SPECIFIED:	PRODUCT SPEC 108-1271 7	NAME TERMINAL, TIMER CONNECTOR	
0 PLC ± - 1 PLC ± - 2 PLC ± 0.25 [.010] 3 PLC ± - 4 PLC ± - ANGLES ± -	SEE TABLE	APPLICATION SPEC 114-49003	SIZE A2	CAGE CODE 00779
MATERIAL H06 BRASS	FINISH	WEIGHT -	DRAWING NO C=770642	RESTRICTED TO -
CUSTOMER DRAWING			SCALE 8:1	SHEET 1 of 1 REV H3